



Dobinsons Spring and Suspension
admin@dobinsons.com
58 Hollingsworth Street
Kawana QUEENSLAND AUSTRALIA 4701

FITTING INSTRUCTIONS PART NUMBER – MRA16-A304

DT RAM FRONT

NOTE – Installation is always recommended by a competent technician. Height not to be adjusted on vehicle.

COMPONENTS	
2 X MRA16-A304 SHOCK ABSORBERS 2 X C92-3013600 COIL SPRINGS 1 KIT RM16-042 (RES MOUNT KIT)	RES MOUNT KIT INCLUDES <ul style="list-style-type: none">• 2 BRACKETS• 4 HOSE CLAMPS• 8 X M6 X 20MM BOLT AND NUTS

Fitting to DT RAM FRONT

1. To set an approx. lift height, see table at end for setting preload. This will get you close to the lift you require.
2. Raise the front end of the vehicle off the ground using a certified jacking system.
3. Support the vehicle using properly rated jack stands. The jack stands should be on the chassis rails of the body. Check the jack stands are locked in place and can handle the weight of the vehicle when it is lowered onto them. Check the vehicle will also not move. The wheels may need chocks to stop them moving.
4. Remove the front wheels.
5. Support the lower control arm with a jack.
6. Loosen sway bar link nut both sides. Sway bar may need to be moved out of way to remove and fit shock absorbers.
7. Remove brake lines if attached to control arms or spindle and move away so it can all lower down without stretching the lines.
8. Remove the spindle from the UCA ball joint. This may require a hit on the spindle housing where it is on the ball joint to loosen it.
9. You may wish to loosen the lower control arm bushes to make it easier to move the arms out of the way. IF you do this, please note the position of the alignment cams.
10. Remove the top 3 nuts on the strut cap. It is important to NOT loosen the middle nut as this is part of the shock absorber.
11. Remove the lower bolts from the shock absorber holding it to the lower control arm. Keep note of the direction this bolt is going as it will need to be put back in the same direction.
12. Remove the strut assembly from the vehicle. It is important to not damage any lines or cv boots. Sometimes you may need to use a lever bar to get it out as the lengths of the shocks may only just fit into the whole suspension setup.
13. Tighten the top bolt which bolts the top cap onto the shock absorber. This should be done up very tight so the cap does not move on the bush steel face. It should be fixed to it so the rubber needs to torsion. This should be tightened at 90 degrees to the body.
14. Install new Dobinsons struts in the existing location. The hose will need to be facing outwards towards the wheels. Check pictures.
15. Place the RESERVOIR MOUNT onto top of the tower. Place the 3 bolts and spring washers in the top cap though the tower into the threaded holes and tighten up to 32 ft lbs torque. See pictures of how reservoir will mount.
16. Install the lower shock fixing bolts into the lower arm through the original mounting holes like original shock absorber. DO NOT TIGHTEN this bolt yet. It should only be tightened at ride height. Make sure the adjuster is accessible to adjust rebound when in the car.
17. Attach the spindle to the lower control arm.
18. Install wheels back onto vehicle.
19. Lower the vehicle onto the ground after jacks are removed.
20. IF the bolts in the inner lower control arms were loosened before at the earlier stage the retighten them up into the original alignment position.
21. Move the vehicle forwards and backwards in a short area (like 2m forward and 2m backward) to allow the vehicle to settle.
22. Tighten the lower shock absorber bolt now the vehicle has settled.
23. The vehicle should now be aligned as soon as possible to minimise any tyre wear.
24. It is good practice to come back after 500 km and check all bolts are tight.

SPRING SEAT AND LEG DIAGRAM

Installing coils to shock absorber

1. Set preload on the top spring seat as per what you want on the table on the next page.
2. Make sure the 2 bolts are taken out and the bottom mounting bracket is removed. Remove the spring seat.
3. The coil will now be able to be place up from the bottom up against the top spring seat. It will need to be compressed to fit the bottom spring seat on.
4. Place the spring seat into the correct location based on the below diagram.
5. Install the 2 bottom bolts and torque up with the bracket in place. The shock is now ready to install.

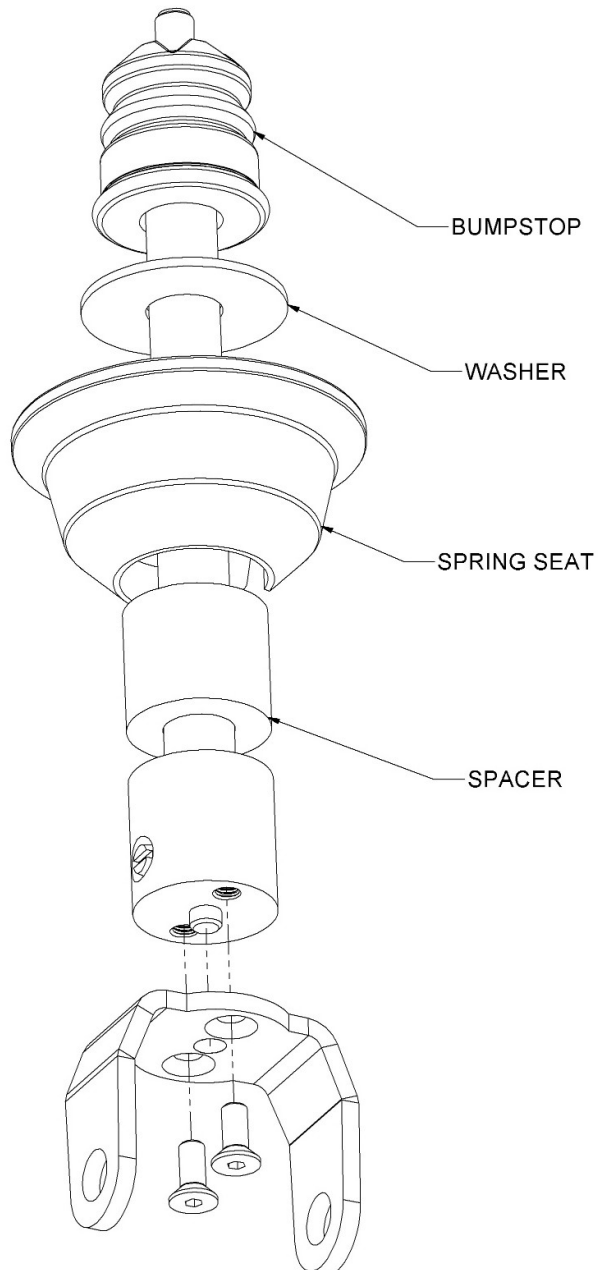

SETTING PRELOAD

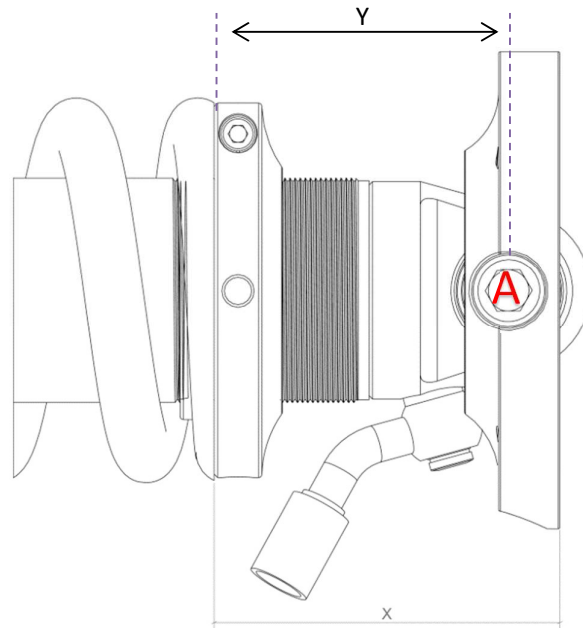

1 – BOLT “A” SHOULD BE TIGHTENED TO 55 FT LBS TORQUE. THIS SHOULD BRING MAKE THE TOP CAP PULL TIGHT ONTO THE BUSH SLEEVE ON THE EYE. IF IT IS NOT TIGHT, YOU CAN APPLY MORE TORQUE. DO NOT GO BEYOND 80 FT LBS OF TORQUE.

2 - PLEASE NOTE LIFT HEIGHTS BELOW ARE APPROX AND VARY DEPENDING ON WEIGHT AND WHERE IT IS PLACED ON THE VEHICLES FRONT AND REAR. FOR EXAMPLE IF LOADING WEIGHT BEYOND THE REAR AXLE, IT CAN LIFT THE FRONT UP.

3 - IF UPGRADING COILS, OR CHANGING COILS, MAKE SURE THE COIL DOES NOT BOTTOM OUT WHEN FULLY COMPRESSED

PRELOAD SETTINGS

Lift Height	Accessories	Seat Height to centre of bolt (Y)	Seat height to top of cap (X)
50mm	0-40kgs	78mm	101mm
50mm	100-120kgs	84mm	107mm
70mm	0-40kgs	83mm	116mm
75mm	50-80kgs	99mm MAX PRELOAD	122mm MAX PRELOAD

FITTING PICTURES

Setting spring seat height



Reservoir Placement



PARTS LIST

Recommended Coil Spring Part Number:

C92-3013600

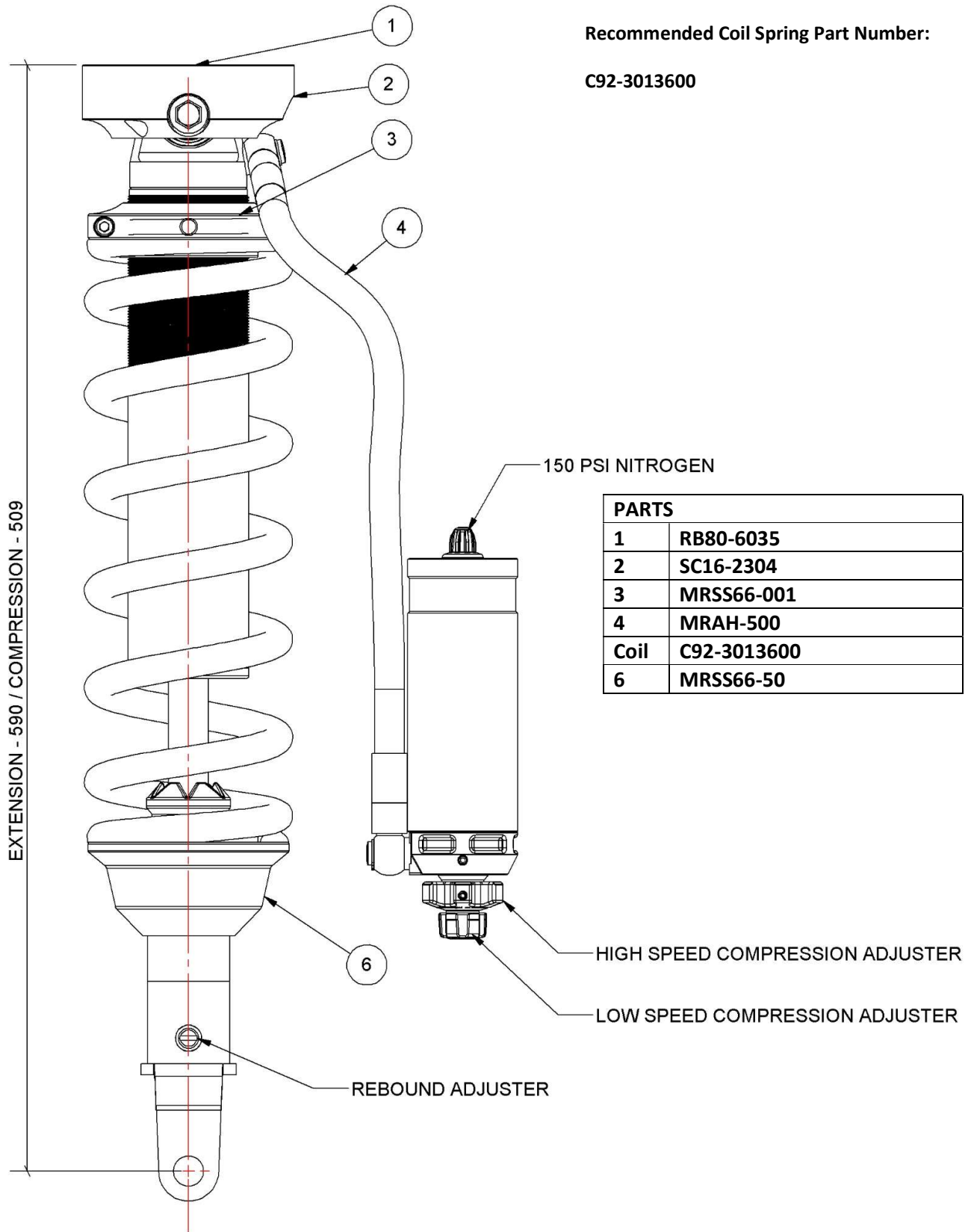

PARTS	
1	RB80-6035
2	SC16-2304
3	MRSS66-001
4	MRAH-500
Coil	C92-3013600
6	MRSS66-50