

Torque Maintenance Guidelines for Dobinsons Billet UCAs

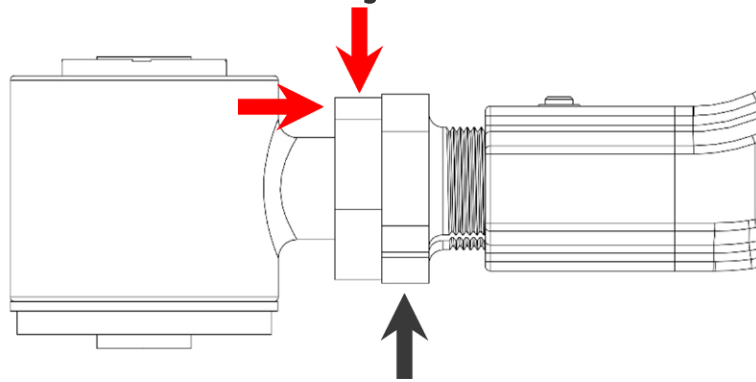

Dobinsons billet UCAs offer adjustable camber settings. To ensure proper performance, it's essential to torque both the jam nut and pinch bolts. Follow this torque schedule: tighten them before installation, again after 500 miles of use, and subsequently every 5,000 miles.

Torque to 70 nm - 51 ft/lb against
the adjuster nut.



On car adjustable nut.

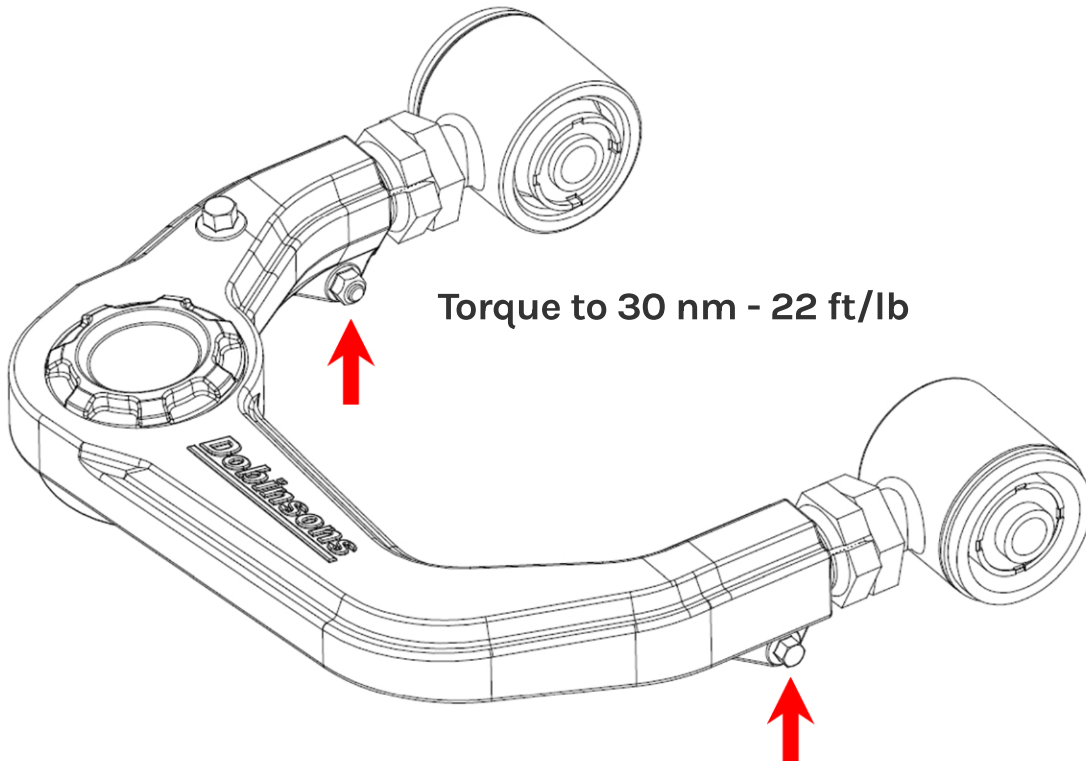

Torque to 30 nm - 22 ft/lb